

(Alternate Type For Jam Nut Type Only)  
S.S. Rope with Ring  
Teflon Coating (N)

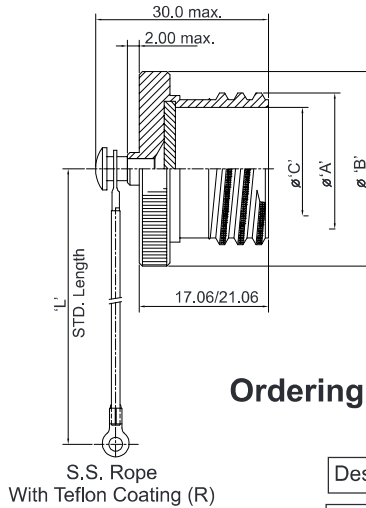

S.S. Rope  
With Teflon Coating (R)

## Ordering Information (Proprietary Part Number)

ITV32 09 A F N H

Designates Plug Dust Cover

Shell Size: 09, 11, 13, 15, 17, 19, 21, 23, & 25

- Class**  
**Aluminium**  
 A - Hard seal nickel finish  
 B - Zinc nickel finish cadmium olive drab  
 F - 48 hrs. electroless nickel  
 T - PTFE Nickel Plating  
 W - 500 Hrs. cadmium olive drab  
 EB - Cad. free zinc cobalt -olive drab finish  
 FB - Cad. free zinc cobalt - black finish  
 T-PTFE nickel finish  
 SD- Zinc Ni Black finish  
**Composite**  
 J - Composite cadmium olive drab  
 M - Composite electroless nickel  
 NB - Nickel Aluminum Bronze  
 CD - S. Steel Passivated

- Type of attachment**  
 D - Bead chain passivated  
 F - Wire rope with teflon jacket  
 G - Nylon cord  
 S - Sash chain passivated  
 X - None

- Type of end link**  
 N - Solid ring  
 T - Tie wrap  
 X - None

**Length of attachment**  
 H - Standard length  
 For non-standard 'H' length has to be specified in mm.

All Dimensions are in mm

Shell Size	'A' Thread -2A -0.1P -0.3L-TS	ØB Max	'C' +0.0 -0.15	ØD Max	ØE Min	'L' + 13.0 -7.0
09	0.625"	23.0	12.50	24.0	13.0	127
11	0.750"	26.0	15.75	27.0	18.0	
13	0.875"	31.0	19.53	30.0	20.0	
15	1.000"	33.0	22.71	31.0	23.0	
17	1.1875"	37.0	25.88	37.0	26.0	
19	1.250"	40.0	28.55	40.0	29.0	
21	1.375"	44.0	31.72	44.0	32.0	
23	1.500"	46.0	34.80	45.0	34.0	
25	1.625"	50.0	38.07	49.0	39.0	

All Dimensions for reference only

## Ordering Information (MIL Part Number)

JAND38999/32 W 15 R

Designates Plug Dust Cover

**Class:-**  
 F - Electroless nikel finish.  
 W- Aluminium,500 hrs cadmium olive drab.

Shell Size : 09,11,13,15,17,19,21,23,&25

**Style-**  
 R - Rope  
 N - With rope & ring.

## Cap without attachment

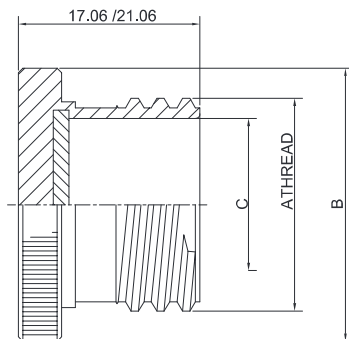

## Ordering information ITV32 - 09 - A - V1

Designates Plug Cover

Shell Size : 09,11,13,15,17,19,21,23 & 25

- Class:**  
 A - Hard Anodic  
 W - Aluminium, 500 hrs. Cadmium Olive Drab  
 J - Composite cadmium olive drab  
 M - Composite electroless nickel  
 F - Aluminium, 48 hrs. electroless nickel  
 EB - Zinc Cobalt Loive drab  
 T- Nickel PTFE finish

Variant